

Playgrounds

- Litzenberg: 6100 US Route 224
- Rawson: 720 River St.
- Swale: 500 N West St.
- Miracle: 3430 N. Main St.
- Civitan: Clinton Ct. at Taylor St.
- Anchor: 215 East St.
- Centennial: Cross Ave, E of Blanchard
- Bernard: 1105 Bernard Ave.
- Emory Adams: 1827 S Blanchard St.
- Firestone: 900 Fifth St.
- Riverside: 231 McManness
- Riverbend: 16618 TR 208
- Brucklacher: 8884 CR 236

Public Tennis Courts

Location	#	Lighted
Rawson, 720 River St.	2	No
Riverside, 231 McManness	2	No
Donnell, 323 Baldwin	3	yes
Findlay HS, 1200 Broad	6	yes
UF, 1600 N Blanchard	6	yes

Pickleball Courts

- Rawson Park - 2 courts
- Riverside Park - 8 courts
- One-Offs?**
- Shuf Fleboard
- Band Shell (Stage)
- Volleyball
- Ice Skating at The Cube, 3430 N Main St

Skateboard Park

- Eagle Creek Park, 526 Hancock St
- Paved Pathways**
- Emory Adams, 1827 S Blanchard
- Westside - 1.2 mi, Eastside - 7 mi
- Miracle Park, 3430 N Main - .45 mi path
- Waterfalls Area Loop, 923 E Main Cross - 1.16 mi
- Water Fun**
- Donnell Pond, 1300 S West St
- Boat Rentals at Riverside Park
- Riverside Pool 231 McManness
- Elk's Swim & Tennis 900 W Melrose
- Country Club, 1500 Country Club Dr
- Canterbury Club, 1828 Queenswood
- Lakeview Club, 15701 Lakeview Pkwy

Nature Trails

- Blue Rock Nature Preserve, 329 E Yates
- Oakwoods Nature Preserve, 1400 Oakwoods Ln
- Litzenberg Memorial Woods, 6100 US-224
- Riverbend, 16618 TR 208
- Findlay Reservoirs - gravel path Around the top
- Dog Park**
- K-9 Field of Dreams Dog Park, 16618 TR 208
- Separate areas: **PTG Dogs** and **Small Dogs**



Picnic Spots

- Riverbend, 16618 TR 208: Picnic shelters, gazebo, grills
- Riverside, 231 McManness: Several covered shelters, grills
- Firestone, 900 Fifth St.: Picnic tables
- Oakwoods, 1400 Oakwoods Ln.: Covered picnic tables at the Discovery Center
- Millstream Art Plaza, Corner of S Main & E Sandusky: Downtown, shaded tables
- Emory Adams, 1827 S Blanchard

Bike It!

- Blanchard River Greenway Bike Path: Broad Ave to Main St. with sections through Riverside Park, River Landings, and West Point.

Disc Golf

- Firestone Park, 900 5th St, 9 holes
- Riverbend Disc Golf Trail, 18 holes stretching 1.8 miles

FootGolf

- Shady Grove, 15733 US 224

Indoor Fun

- Children's Museum, in the mall
- Open Family Gym, XT Fitness, 2725 N Main
- YMCA, 300 E Lincoln St
- Mall Trail, "800 Tiffin Ave - Take a lap around the mall"

Fishin' spots

- Findlay Reservoirs, near Riverbend on TR 207
- Old Lake at Oakwoods
- Shank Lake at Oakwoods
- Giertz Lake at Riverbend
- The Mighty Blanchard River

HOW TO FOLD A ZINE

Key:

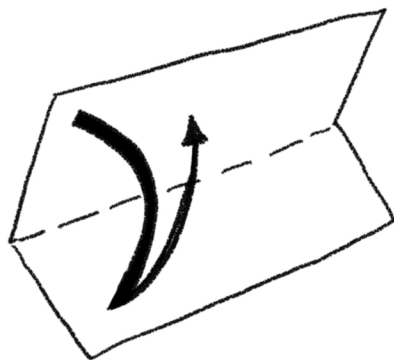
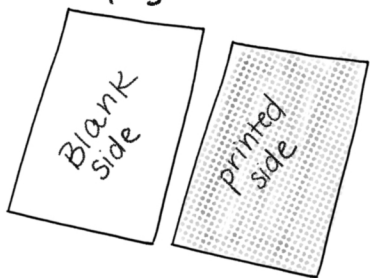

① Fold hotdog style. Unfold

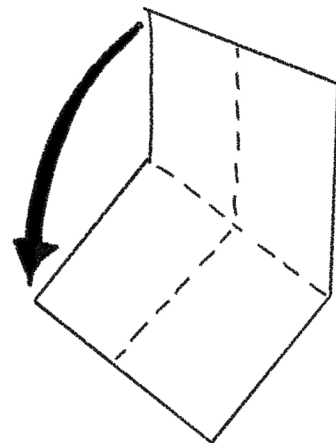

② Fold hamburger style.

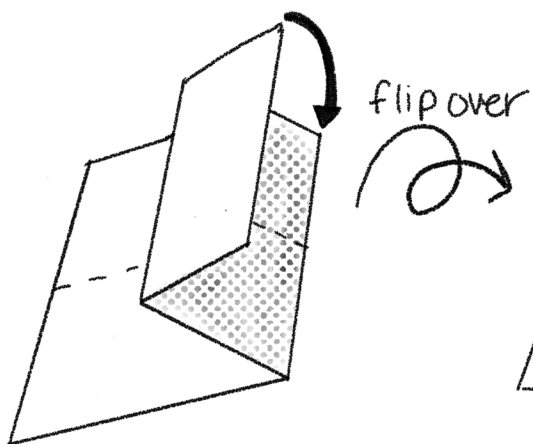

③ Fold edge to center fold

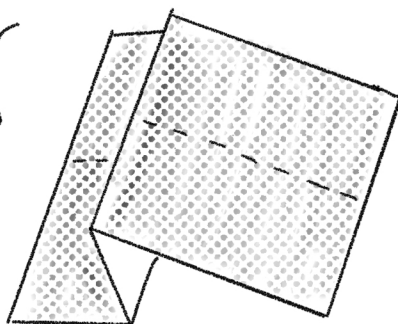

then →

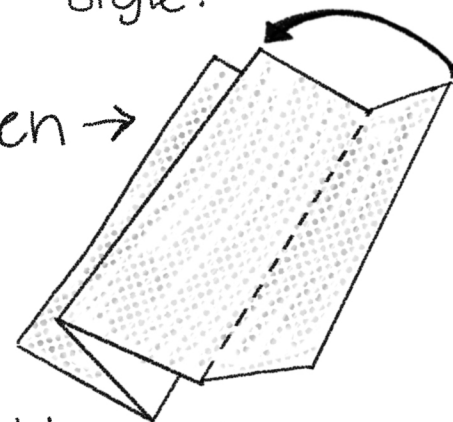

④ Fold remaining edge to center fold.

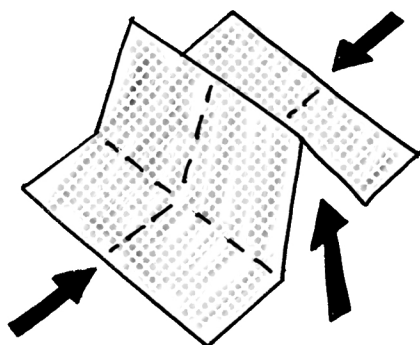

⑤ Make a mountain.

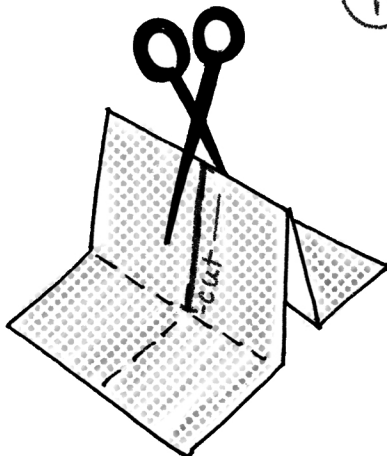

6. Cut

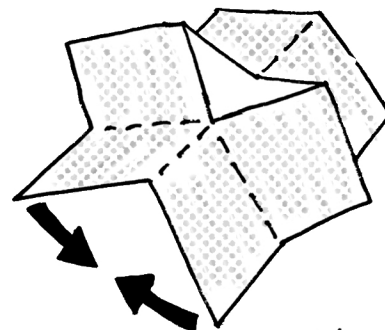

7. Grasp either side of cut. Fold down.

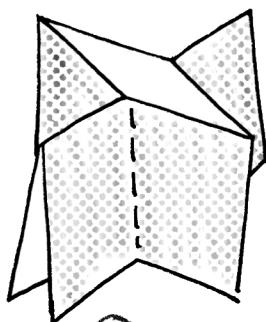

⑧

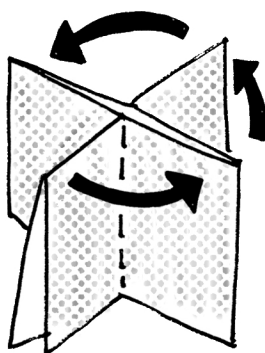

⑨



10